

WOHNÜBERBAUUNG WOLFGANGHOF SÜD

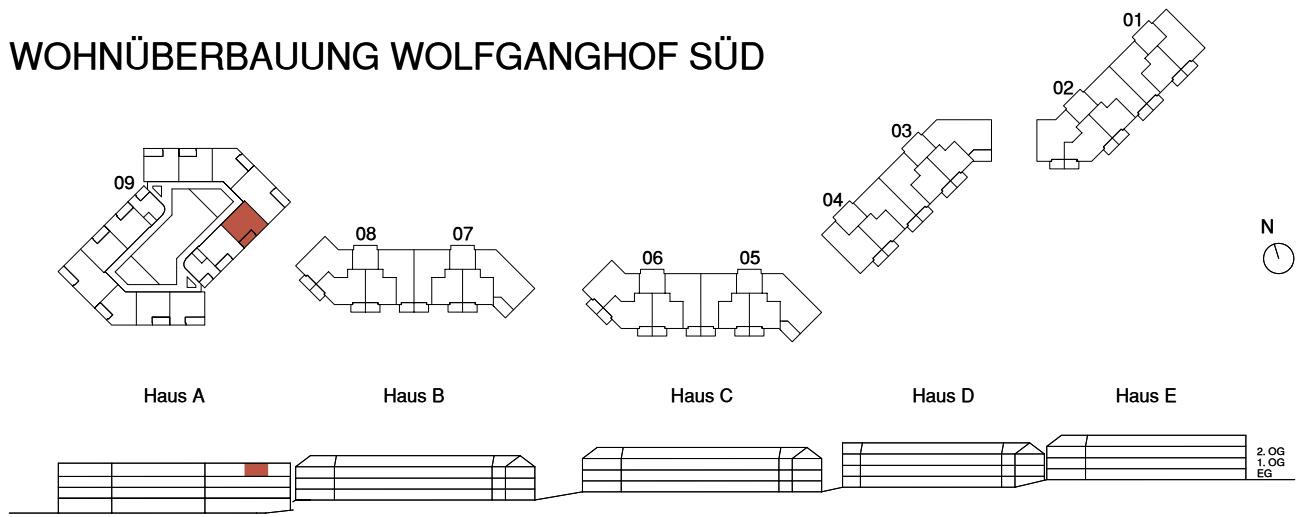

Adresse
Wolfgangstrasse 80, 9014 St. Gallen

Haus A

Stockwerk
3. Obergeschoss

Wohnung
09.3005

Anzahl Zimmer
2,5

Nettowoohn-/ Balkonfläche
53.7 m² / 8.9 m²

