

# WOHNÜBERBAUUNG WOLFGANGHOF SÜD

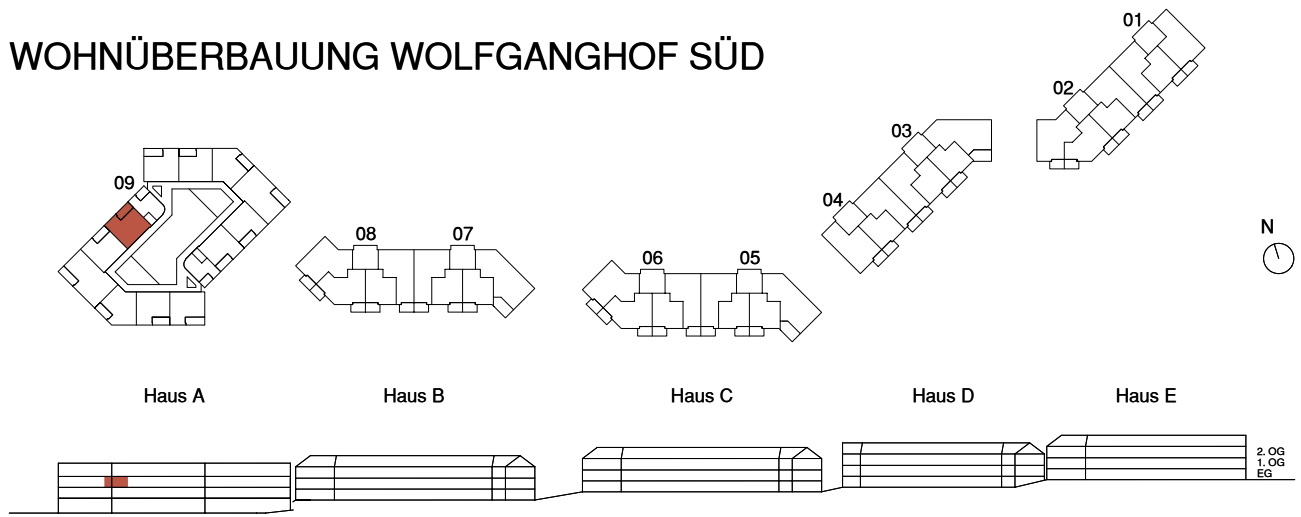

Adresse  
Wolfgangstrasse 80, 9014 St. Gallen

Haus A

Stockwerk  
2. Obergeschoss

Wohnung  
09.2013

Anzahl Zimmer  
2.5

Nettowohn-/ Balkonfläche  
53.7 m<sup>2</sup> / 8.2 m<sup>2</sup>

