

# WOHNÜBERBAUUNG WOLFGANGHOF SÜD

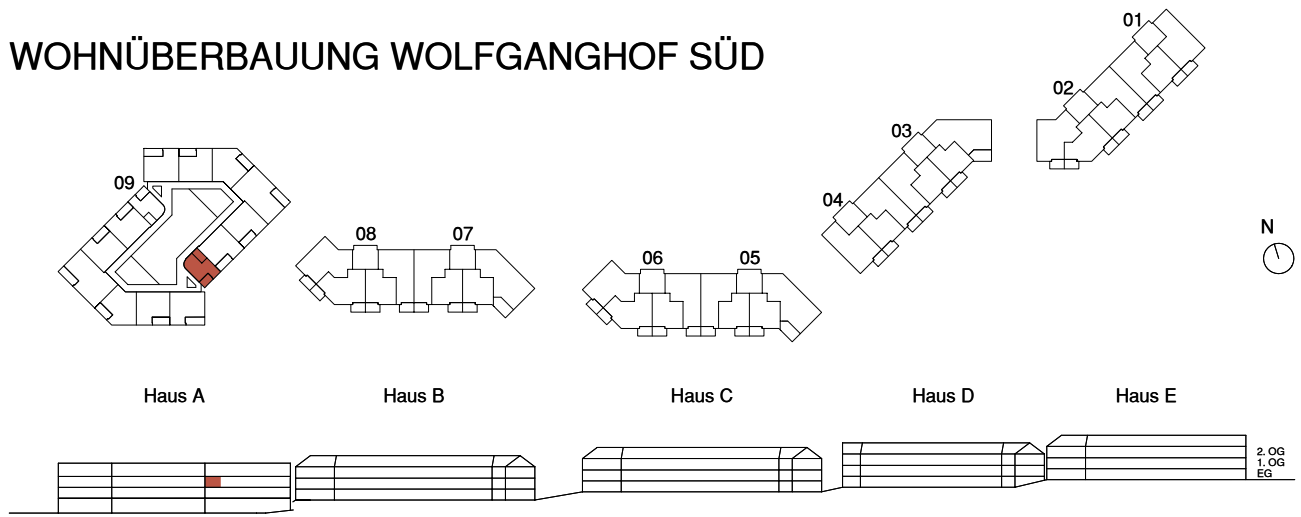

Adresse  
Wolfgangstrasse 80, 9014 St. Gallen

Haus A

Stockwerk  
2. Obergeschoss

Wohnung  
09.2007

Anzahl Zimmer  
1.5

Nettowohn-/ Balkonfläche  
28.9 m<sup>2</sup> / 5.0 m<sup>2</sup>

